

ET7300



TRAPEZOIDAL TRENCHER

Depth: up to 8'-0" (2.44m)

Bottom Width: 1'-0" (0.30 m) to 8'-6" (2.50 m)



G&Z produces the highest production, lowest operating cost Wheel Trenchers available on the market today. Combining years of field and manufacturing experience, and utilization of the latest technology, makes Eagle Trenchers the most cost effective way to increase productivity and profitability.

Depending on your canal cross section, the Eagle 7300 can excavate and trim the canal cross section in a single pass. Powered by a 385 HP (287 kW) diesel engine, the Eagle 7300 Trapezoidal Trencher is rugged enough for the toughest jobs. All machine functions are electric over hydraulic and all controls are well marked and positioned for ease of operation, safety, and optimum operator visibility. The digging wheel is pivot connected to the tractor allowing canals with limited radius curves to be built. The Eagle 7300 is self-moving for ease of moving around obstructions in the canal alignment.



EAGLE 7300 TRAPEZOIDAL TRENCHER

STANDARD FEATURES

- **Engine:** 6 cylinder, air-cooled, Diesel, US EPA Tier 3 / EU Stage IIIA compliant, turbocharged, 385 HP (287kW) at 2100rpm, Continuous Rating
- **Depth:** 1'-6" (0.46m) minimum / 8'-0" (2.50m) maximum depending on the maximum depth.
- **Slopes:** 1:1, 1.25:1, and 1.5:1 as ordered. Some limitations may apply.
- **Bottom Width:** 12" (0.3m) Bucket (nominal) to 8'-6" (2.50m) maximum cut depending on slope and depth. Consult with G&Z factory on your exact canal cross sections
- **Teeth:** Hensley X156 or equivalent with roll pin
- **Digging Wheel:** Hydraulic Motor Drive mounted directly to the wheel head shaft with bolt-on, cast steel split sprockets driving off the wheel rim segments center pull, articulated pivot mast connected to the tractor for curves.
- **Wheel Rim:** False style rims with weld-on cast steel segment
- **Rotary Drive:** Rotary output shaft driven off bolt-on, "bull gear" running off bucket wheel rim segments. Bull gear drives outer slope rotaries.
- **Manual/Automatic Steering and Elevation Control:** Includes sensors, adjustable supports, and cross slope control in reference to

a single stringline

- **Hydraulically Adjustable Counterweight**
- **Conveyor:** Reversible hydraulic drive for either right or left conveyor discharge, 42" (1067mm) wide and up to 20'-11" x (6.375m) long. The conveyor length is custom made to fit your application and is rated @ 0 - 1000fpm (0 - 305m/min). Includes hydraulic conveyor shift mechanism
- **Undercarriage:** G&Z D-5 size Crawlers, track chain with split master link. High reduction planetary gearboxes. Undercarriage mounted to a separate subframe, and center pin connected to the tractor body. Machine equipped with Cross Level Control System which includes hydraulic cylinders for cross level control for 15 degree maximum angle
- **Speed Range:**
 - Working Speed: 0 - 29 fpm (0 - 8.8m/min)
 - Travel Speed: 0 - 186 fpm (0 - 56m/min)
- **Weight:** Approx. 100,000lbs-130,000lbs (45,359-58,967kg) depending on configuration
- **Lighting:** DC Night Lighting System which includes 4ea LED Lamps
- **Operator Cabin:** Includes heating / air conditioning
- **Back up alarm**

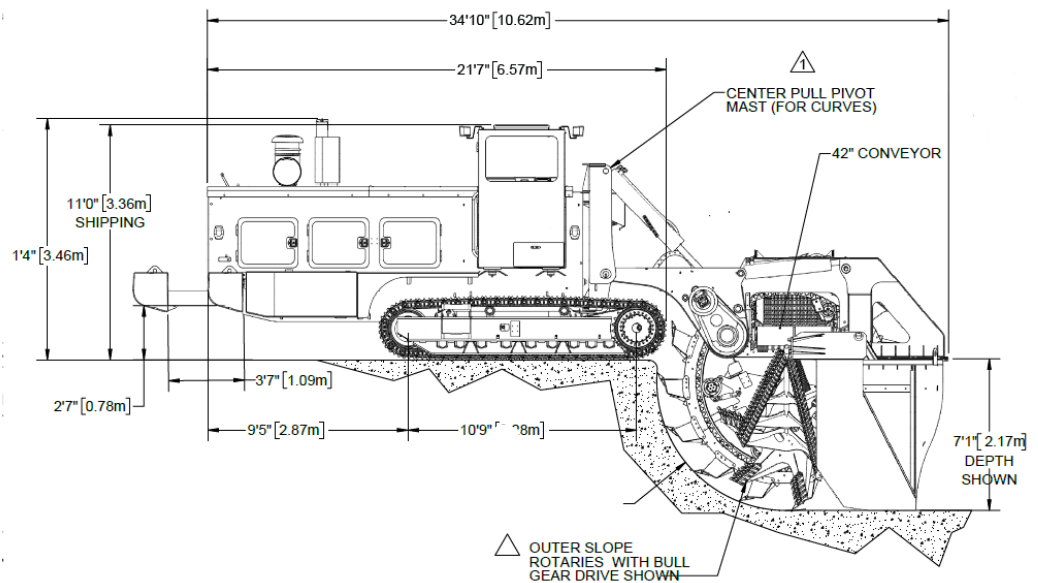
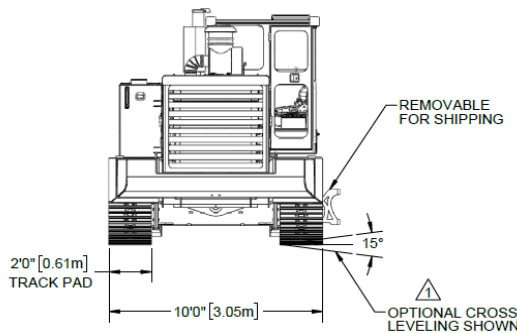

OPTIONAL FEATURES

- Operator Cabin Air Pressurization System
- Utility/Pipeline trencher conversion kit
- Laser Control Equipment
- Additional buckets, rotaries, and crumbshoes for different canal cross sections and slopes. Consult with G&Z Factory
- US EPA Tier 4f/EU Stage IV Diesel Engine